

SECTION - 3

LENS COUPLING CONFIGURATIONS

- a) SPHERICAL POLISHED STRUCTURES
- b) SPHERICALLY ENDED OR TAPERED FIBER COUPLING
- c) TRUNCATED MICROLENSES
- d) GRIN-ROD LENSES
- e) INTEGRAL LENS STRUCTURE

Note : LED output is not fully coupled into the fiber because of narrow acceptance angle of the fiber.

Spherical-Ended Fiber Coupled AlGaAs LED

Zn DIFFUSED p-LAYER

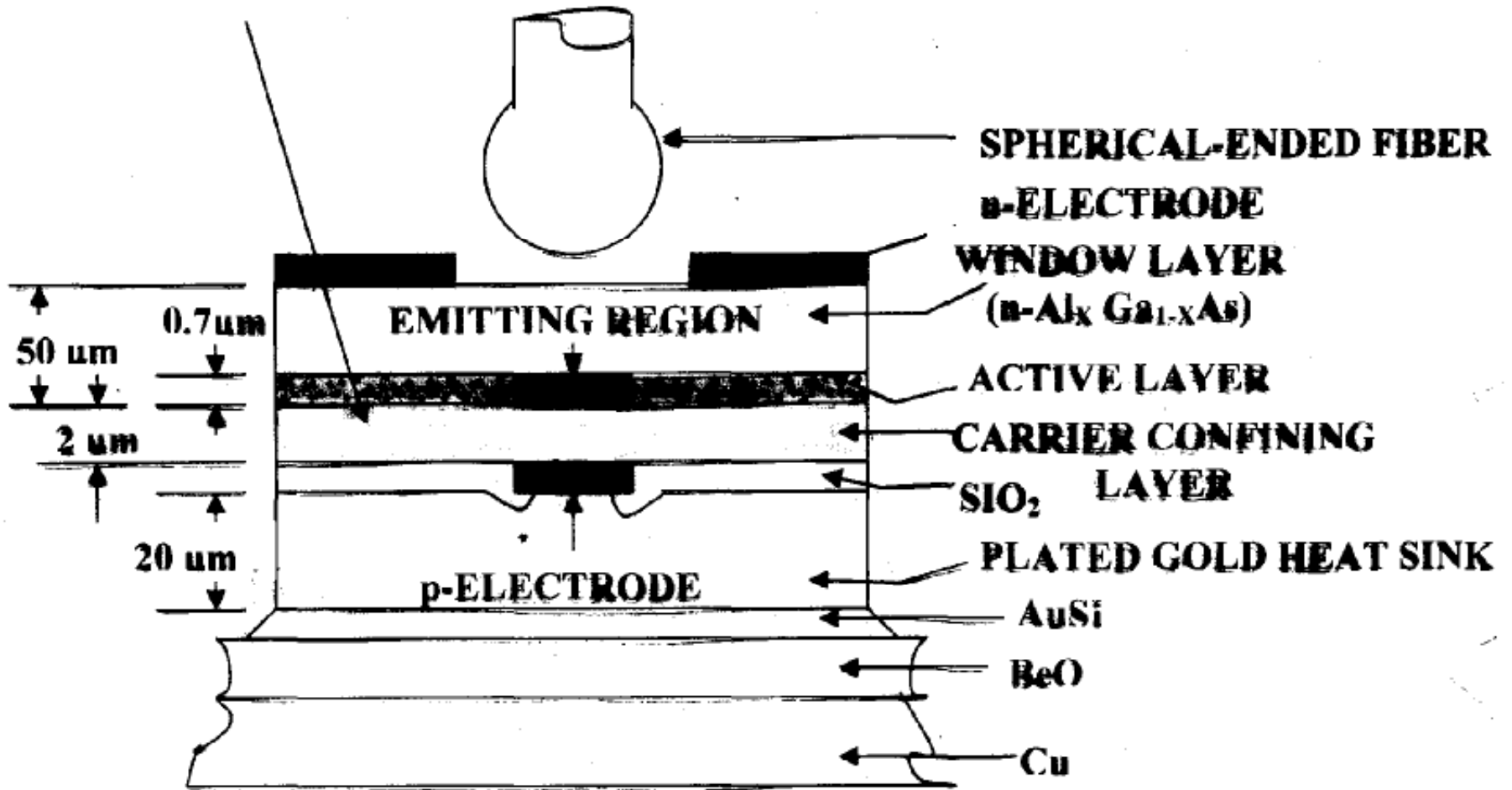

SPHERICALLY ENDED FIBER COUPLED Al Ga As LED

- EMITTING DIA = 35 μm
 - CORE DIA (OF FIBER)= 75 – 110 μm
- } RATIO OF
1: 2 (min)
- COUPLING EFFICIENCY OF 2 TO 5 TIMES CAN BE ACHIEVED THR THE USE OF SPHERICAL FIBER LENS.
 - THE DEVICE IS A PLANAR SURFACE EMITTING STRUCTURE WITH THE SPHERICAL ENDED FIBER ATTACHED TO THE CAP BY EPOXY RESIN.
 - **COUPLING EFFICIENCY = 6 %**

USE OF TRUNCATED SPHERICAL MICROLENS FOR COUPLING THE EMISSION FROM AN InGaAsP surface EMITTING LED

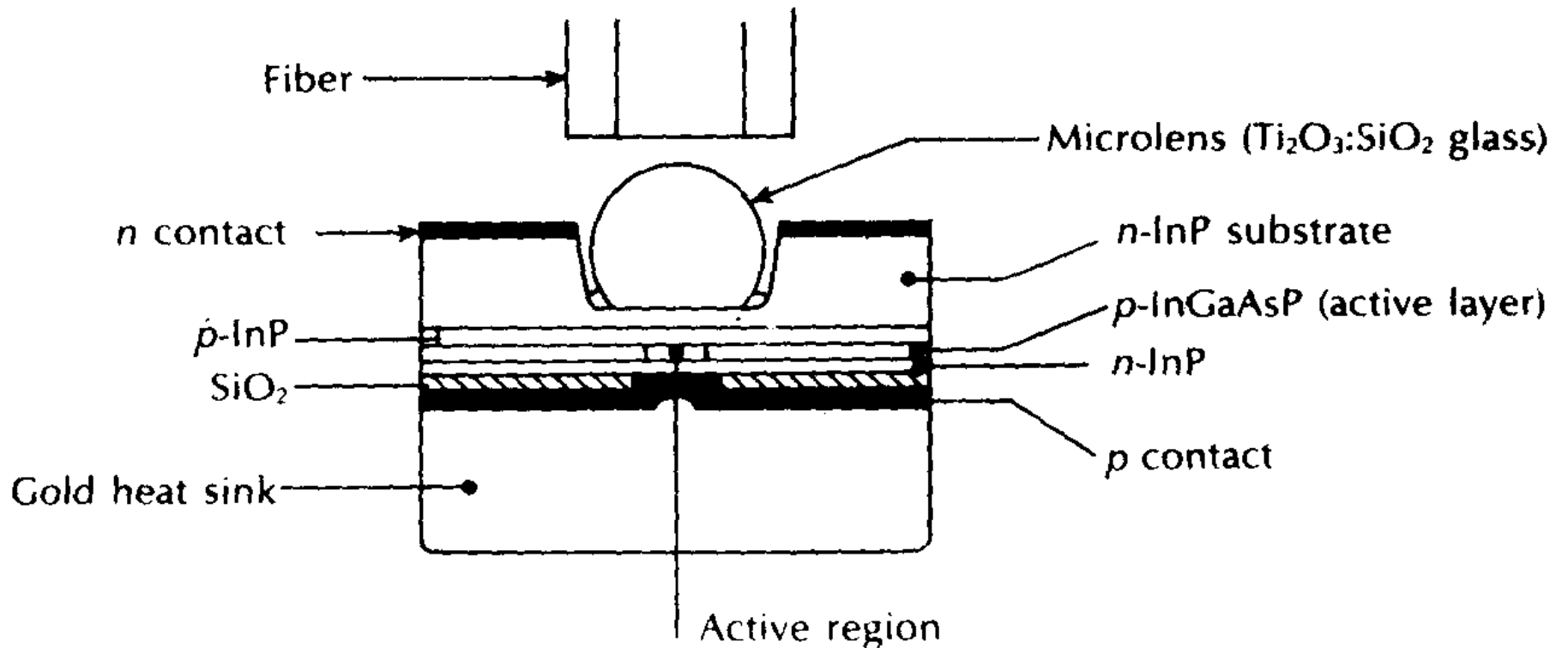

- OPERATING wave length = 1.3 μm
- EMISSION REGION DIA SHOULD BE MUCH SMALLER THAN CORE DIA OF THE FIBER.
- **TYPICAL VALUES (for a step Index fiber)**
- ACTIVE DIA : 14 μm
- CORE DIA : 85 μm
- NUM APERTURE : 0.16

COUPLING η INCREASED BY A FACTOR OF 13.

OVERALL POWER CONVERSION EFFICIENCY (η_{PC})

$$\left(\frac{\text{OPT POWER COUPLED INTO FIBER}}{\text{ELECT. POWER APPLIED AT TERMIALS}} \right) \text{ IS STILL LOW= } \mathbf{0.4\%}$$

NOTE : THEORY SUGGESTS POSSIBLE INCREASE OF UPTO 30 TIMES IN THE COUPLING η)

LENS COUPLING WITH EDGE EMITTING LED'S

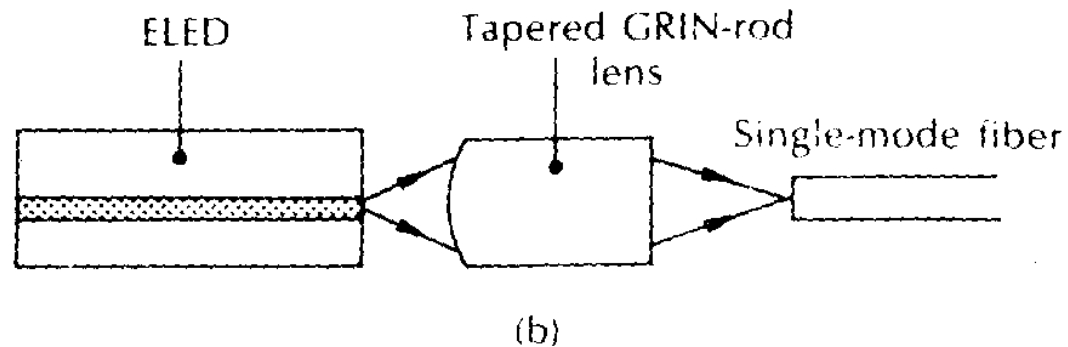
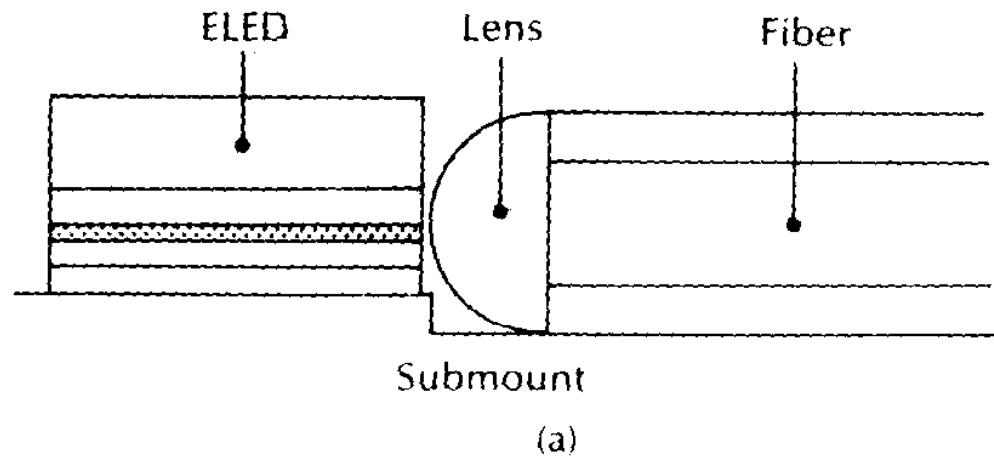

Lens coupling with edge-emitting LEDs: (a) lens-ended fiber coupling; (b) tapered (plano-convex) GRIN-rod lens coupling to single-mode fiber.

LENS COUPLING WITH EDGE EMITTING LED'S

- HIGHER POWER CAN BE COUPLED INTO SINGLE MODE FIBERS IN CASE OF EDGE EMITTING LED'S THAN SELED'S.
- **TAPERED FIBER – LENSES YIELD A COUPLING EFFICIENCY OF 15%**
- **COUPLING, $\eta = \frac{\text{COUPLED POWER}}{\text{TOTAL EMITTED POWER}}$**
 - A) LENS – ENDED FIBER COUPLING
 - B) TAPERED (PLANO - CONVEX) GRIN – ROD LENS COUPLING TO SINGLE MODE FIBER.

LED CHARACTERISTICS

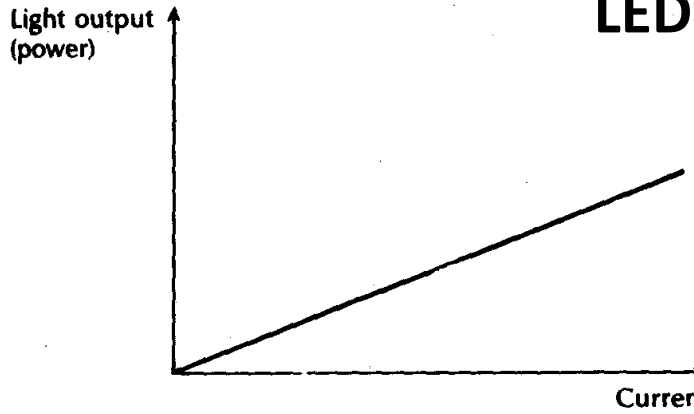

An ideal light output against current

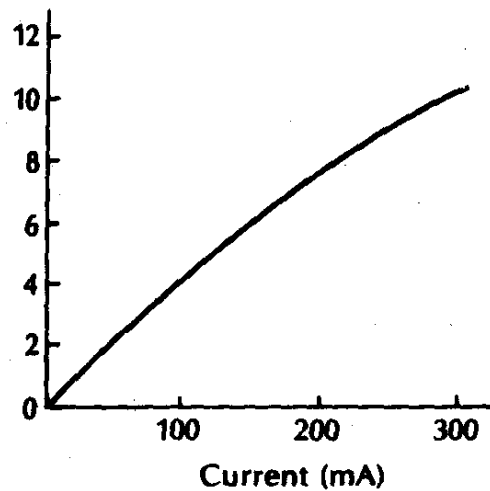

(a)

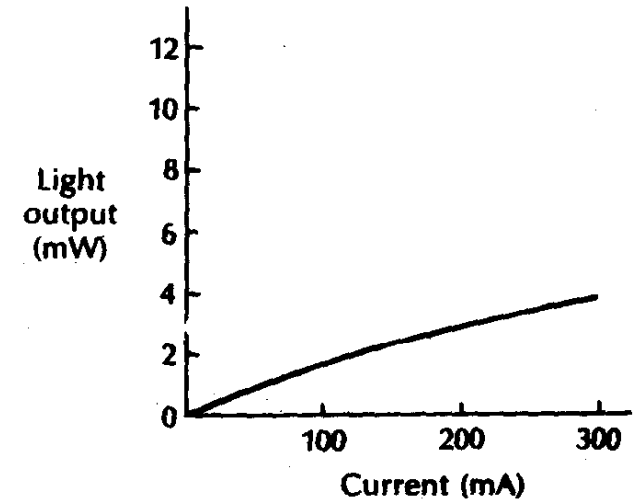

(b)

(a) An AlGaAs **surface emitter** with a 50 μm diameter

(b) An AlGaAs **edge emitter** with a 65 μm wide stripe and 100 μm length.

SURFACE EMITTER LED RADIATES SIGNIFICANTLY MORE OPTICAL POWER THAN EDGE EMITTER LED.

BOTH ARE REASONABLY LINEAR AT MODERATE CURRENTS

LIGHT OUTPUT TEMP. DEPENDENCE-LED

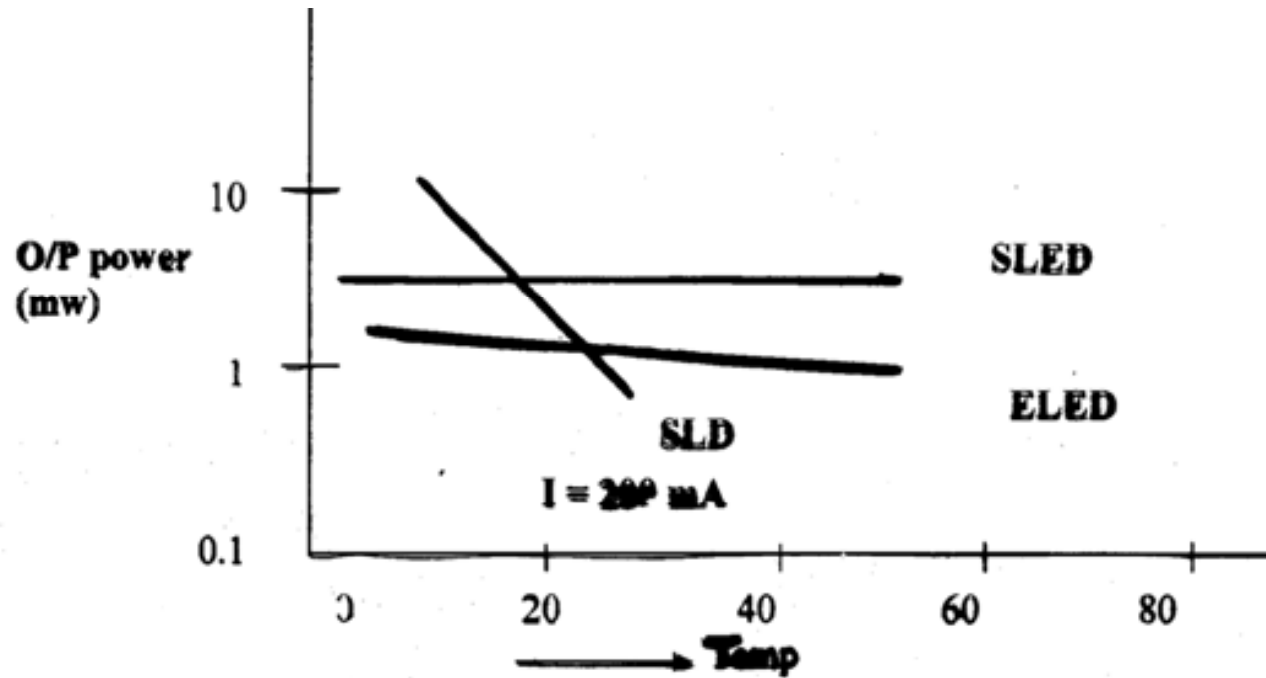

- THE INTERNAL QUANTUM EFFICIENCY OF LED'S DECREASES EXPONENTIALLY WITH INCREASING TEMPERATURE & SO THE LIGHT OUTPUT DECREASES AS P-N JUNCTION TEMPERATURE INCREASES.
- ELED EXHIBITS GREATER TEMPERATURE DEPENDENCE THAN SLED
- OUTPUT OF SLD WITH ITS STIMULATED EMISSION IS STRONGLY DEPENDANT ON THE JUNCTION TEMPERATURE.

CURVES FOR AN AlGaAs SURFACE EMITTING LED

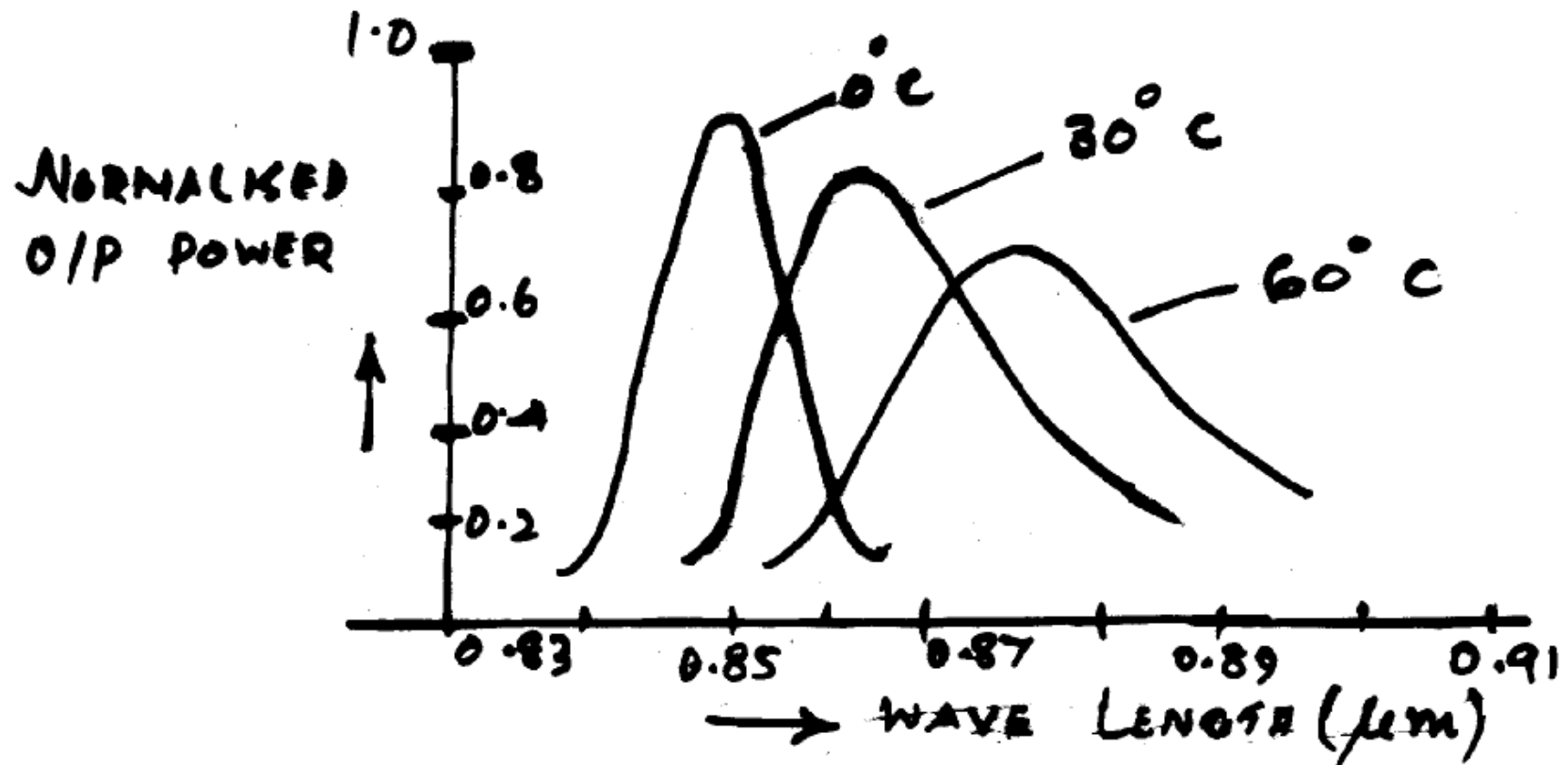

OUTPUT SPECTRA TENDS TO BROADEN AT A RATE 0.1 TO 0.3 nm/deg INCREASE IN TEMP. (DUE TO GREATER ENERGY SPREAD IN CARRIER DISTRIBUTIONS)

OUTPUT SPECTRUM

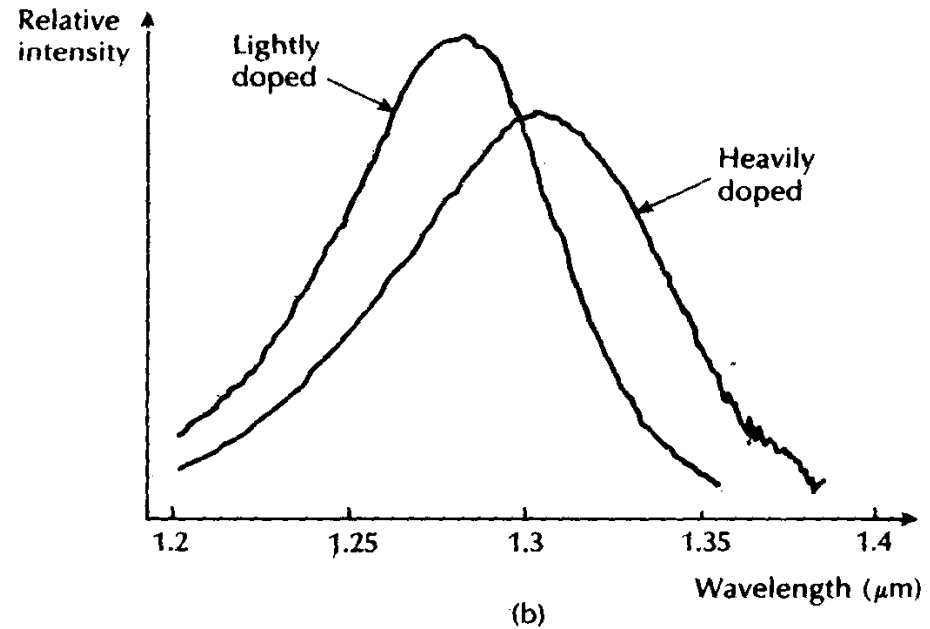
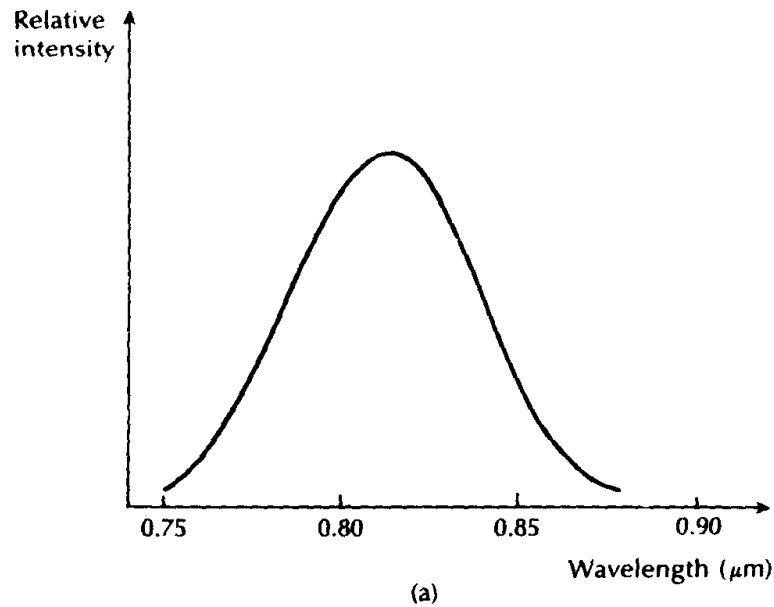

LED output spectra: (a) For an AlGaAs surface emitter with doped active region
(b) For an InGaAsP surface emitter showing both the lightly doped and heavily doped cases.

-SPECTRAL LINEWIDTH OF LED OPERATING AT ROOM TEMP IN THE 0.8 TO 0.9 μm WAVELENGTH BAND IS 25 – 40 nm AT HALF POWER POINTS .

LINE WIDTH INCREASES DUE TO INCREASED DOPING LEVELS.

-TYPICAL VALUES FOR ELED & SLED IS 75 nm & 125 nm RESP at 1.3 μm

MODULATION

- TO TRANSMIT INFORMATION, IT IS NECESSARY TO MODULATE A PROPERTY OF THE LIGHT, WITH THE INFORMATION SIGNAL.
- **PROPERTY : INTENSITY, FREQUENCY, PHASE, POLARISATION (DIRECTION)**

INTENSITY MODULATION (IM) OF THE SOURCE IS THE MAJOR MODULATION STRATEGY.

- IM IS EASY TO IMPLEMENT (variation of drive current of the source)
- ANALOG INTENSITY MODULATION IS USUALLY EASIER TO APPLY BUT REQUIRES LARGE S/N RATIO , AND HENCE LIMITED TO SHORT DISTANCE APPLICATIONS (NARROW BW).
- **DIGITAL INTENSITY MODULATION GIVES IMPROVED NOISE IMMUNITY , BUT REQUIRES WIDER BW'S.** IDEALLY SUITED FOR OFC, AS LARGE BW IS AVAILABLE .

MODULATION BANDWIDTH

ELECTRICAL DEFINITION :

ELECTRICAL SIGNAL POWER HAS DROPPED TO HALF ITS CONSTANT VALUE DUE TO MODULATED PORTION OF THE OPTICAL SIGNAL (3 DB DOWN).

THIS CORRESPONDS TO THE FREQ AT WHICH ELECTRICAL POWER IS REDUCED BY 3 db w.r.t I/P ELECTRICAL POWER i.e WHEN OUTPUT CURRENT HAS DROPPED TO 0.707 OF INPUT CURRENT.

MODULATION BANDWIDTH

MODULATION BANDWIDTH (OPTICAL) :

FREQUENCY RANGE BETWEEN ZERO AND THIS HIGH FREQUENCY 3 DB POINT **WHEN OUTPUT CURRENT HAS DROPPED TO 0.5 OF THE INPUT CURRENT.**

OPTICAL BANDWIDTH IS NORMALLY $\sqrt{2}$ TIMES GREATER THAN THE ELECTRICAL BANDWIDTH.

MODULATION BANDWIDTH (ELECT & OPTICAL)

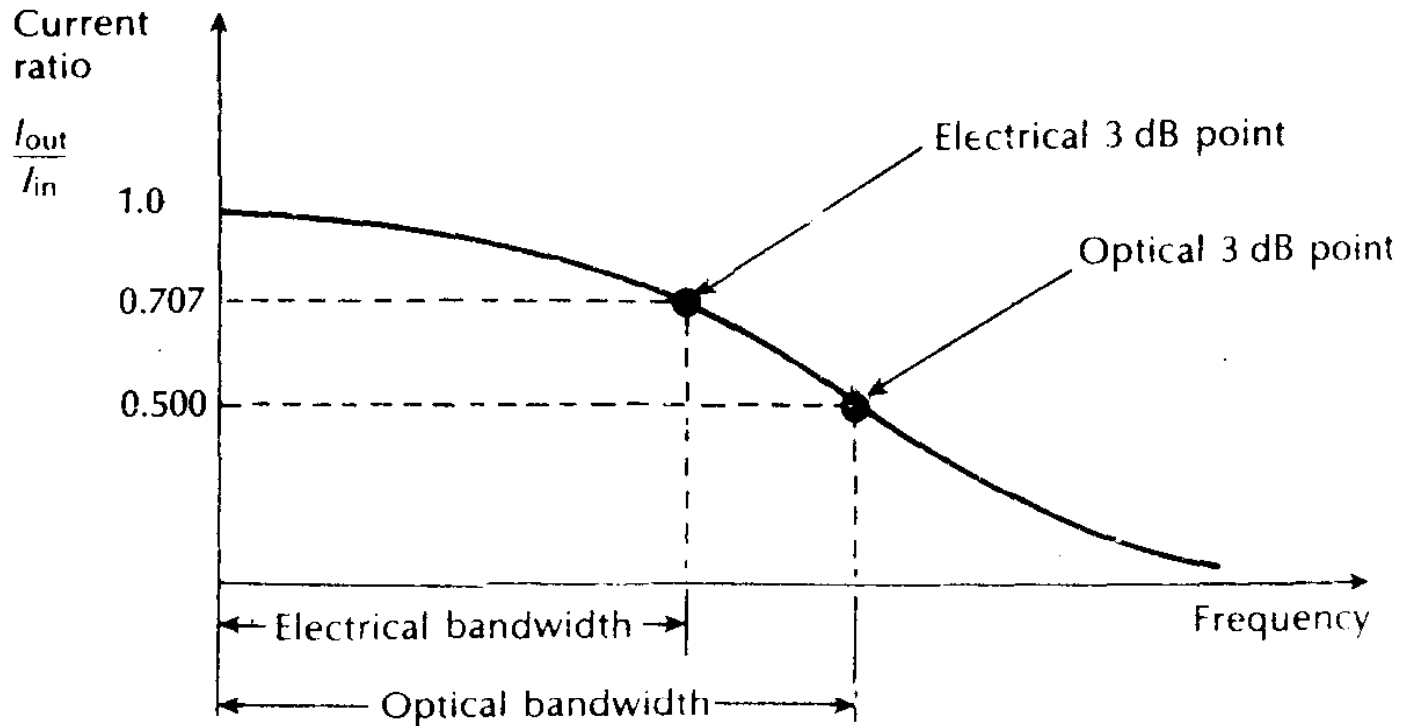

RATIO OF ELECT. O/P POWER TO ELECT I/P POWER IN db = RE db

R E db = 10 Log₁₀ Elect POWER OUT (DET) / Elect POWER IN(SOURCE)

$\alpha 10 \text{ Log}_{10} [I_{out}/I_{in}]^2$

AT 3db $(I_{out} / I_{in})^2 = 1/2$

$I_{out} / I_{in} = 1/\sqrt{2} = 0.707$

$$RO = 10 \log_{10} \frac{\text{OPT power out (DET)}}{\text{OPT power in (SOURCE)}}$$

$$= 10 \log_{10} \frac{I_{\text{out}}}{I_{\text{in}}} \quad \text{At 3 db} \quad \frac{I_{\text{out}}}{I_{\text{in}}} = 1/2$$

(Due to linear light/ current relationship) of the source and detector

$$\text{Opt. BW} = \sqrt{2} (\text{Elect BW})$$

RELIABILITY OF LED'S

- LED'S EXHIBIT GRADUAL DEGRADATION IN ADDITION TO RAPID DEGRADATION.
- RAPID DEGRADATION IS DUE TO GROWTH OF DISLOCATIONS AND PRECIPITATE – TYPE DEFECTS IN ACTIVE REGION (CALLED DLDs & DSDs)
- THESE DEFECTS DEPEND UPON INJECTION CURRENT DENSITY, TEMP & IMPURITY CONCENTRATION.
- LONG TERM DEGRADATION COULD BE DUE TO MIGRATION OF IMPURITIES INTO THE ACTIVE REGION.

RELIABILITY(contd)

- Output power

P_{out} : INITIAL O/P POWER

β_r : DEGRADATION RATE = $\beta_0 e^{-E_a/KT}$

Where β_0 – PROPORTIONALITY CONSTANT
K- BOLTZMAN'S CONSTANT

OPT. POWER O/P $P_e(t) = P_{out} e^{-\beta_r t}$

T- ABS. TEMP. OF THE EMITTING REGION.

E_a – ACTIVATION ENERGY ≈ 0.56 TO 1.0 eV FOR SLED'S
(dependant upon material and structure of device)

AVG. LIFE OF SLED'S

- 10^6 TO 10^7 HOURS(100 TO 1000 YRS)

(FOR CW OPERATION AT ROOM TEMP FOR AlGaAs DEVICES)

- IN EXCESS OF 10^9 HRS FOR SURFACE EMITTING InGaAsP LED'S.

- DEVICE LIFE TIME IS OFTEN DETERMINED FOR A 50% DROP IN LIGHT OUTPUT FROM THE DEVICE

- JUNCTION TEMP, EVEN FOR A DEVICE OPERATING AT ROOM TEMP. IS LIKELY TO BE WELL IN EXCESS OF ROOM TEMP, WHEN SUBSTANTIAL DRIVE CURRENTS ARE PASSED